



Product information
Website will be opened in
November 2021



Technical documents
Download from PRO CLUB
NX series technical document
will be available in November 2021.

PACKAGED AIR CONDITIONER NX SERIES 2021/2022



Panasonic®

**Building Passion,
Building Solutions.**
Panasonic Air Conditioning Systems

We face a time in which "quality air" differentiates business. It's a time for Panasonic to fully display its strengths. Our ability to assemble and build superior systems isn't just due to the rich resources we have as a comprehensive electronics manufacturer, but also to Panasonic's 100 years of tradition, where each person thinks and acts on their own initiative while working in a team to reach further heights. We do not compromise. Each of our independent selves is a one stop solution. We face our customers' challenges together with our customers and do all that we can to build effective systems. As a true partner for our customers, we strive to always be at the forefront of business.

- Please read the Installation Instructions carefully before installing the unit, and the Operating Instructions before using it.
- Specifications are subject to change without prior notice.
- The contents of this catalogue are accurate as of November 2021.
- Due to printing considerations, the actual colours may vary slightly from those shown.
- All graphics are provided merely for the purpose of illustrating a point.



Do not add or replace refrigerant other than the specified type. Manufacturer is not responsible for the damage and deterioration in safety due to usage of other refrigerant.

Authorised Dealer

PAC INVERTER ASIA November 2021



nanoeX



INVERTER



Panasonic Air-Conditioning Indonesia







A Better Life, A Better World

QUALITY AIR FOR LIFE

NX Series Product Lineup

- 3-phase model newly added
- Indoor unit model name unification for better supply chain management.
- Use In-house manufactured compressor

Capacity [Btu/h (Phase)]		17,100	20,500	24,200	27,600/29,000	34,100	42,700	45,500-47,800
4-way Cassette •nanoeX		S-1821PU3H		S-2430PU3H			S-3448PU3H	
Adaptive Ducted •nanoeX		S-1821PF3H		S-2430PF3H			S-3448PF3H	
Ceiling Exposed •nanoeX		S-1821PT3H		S-2430PT3H			S-3448PT3H	
Outdoor 1-phase		U-18PR1H5	U-21PR1H5	U-24PR1H5	U-30PR1H5	U-34PR1H5	U-43PR1H5	U-48PR1H5
Outdoor 3-phase		—	—	—	—	—	U-43PR1H8	U-48PR1H8

NEW /// 24-hour nanoe™ X Air Protection

Get 24 hours of quality air for you and your loved ones by turning nanoe™ X on using Panasonic Comfort Cloud anywhere, anytime. nanoe™ X functions in the cooling mode and is maintenance-free, helping you enjoy cleaner air while keeping your costs down.





Please refer to the nanoe™ X website.



7 Effects of nanoe™ X : Creating Cleaner Environments

nanoe™ inhibits 5 types of pollutants, deodorises and moisturises thanks to the action of hydroxyl radicals contained in water.

 Deodorises Odours	 Inhibits 5 types of pollutants Bacteria & viruses Mould Allergens Pollen Hazardous substances	 Moisturises Skin & Hair
--	--	--



nanoe™ X Effectiveness Proven in Large Space

Access to the evidence page of nanoe™ X effect

NEW ///

Flexible Installation Adaptive Ducted

New NX Series Adaptive Ducted units can be mounted not only horizontally but also vertically without the need for alterations. Our groundbreaking drain pan design delivers a new level of flexibility in an industry-leading vertical installation.



Product information Website will be opened in November 2021

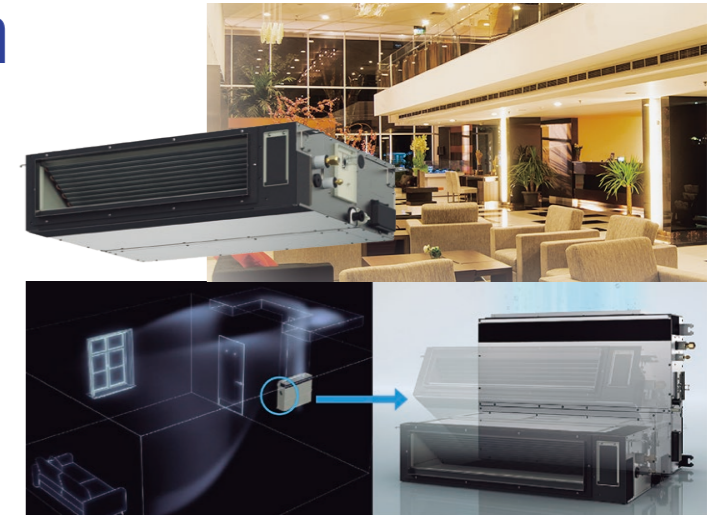

Compact Body with Powerful 150 Pa ESP

The indoor units have also been completely renewed, offering a 40 mm height reduction to only 250 mm* and a weight reduction of up to 10%, all while maintaining the same powerful 150 Pa.

* Compared to conventional model.

Space saving 250 mm height

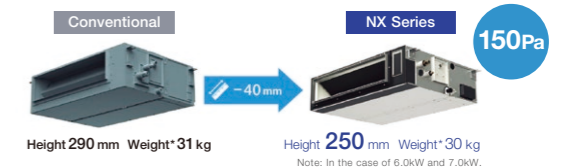

NEW ///

Smart Comfort with CONEX

CONEX offers IoT integration that connects directly to a variety of apps for next-generation solutions. Easy control and access for end users, installers, and service partners with just one remote.





Access to the evidence page of conex Website will be opened in November 2021



New CONEX Control
New smart design with built-in BLE & WLAN model.



- 
Comfort Cloud-End User
 High level control and energy monitoring via WLAN and cloud giving access from anywhere anytime.
- 
H&C Control App-End User & Installer
 H&C Control App makes complex initial set-up easy and allows installers to respond swiftly to clients' requests via Bluetooth.
- 
H&C Diagnosis App-Service Partner
 Provides the service partner with detailed operational data, for in-depth analysis and optimising the system.

Advantages of New 4-way Cassette

Compact, Modern & Flat Panel Design

Featuring uniform cooling, easy installation, and with a sleek exterior, this unit is the perfect match for all commercial applications.

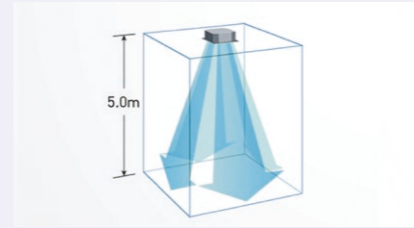
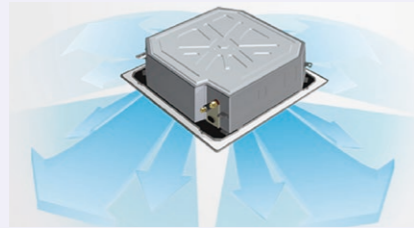

Powerful Airflow

Thanks to its compact design the Twisted 3D Blade Fan increases airflow.

360° Comfortable Airflow

Air coming out of the centre of the discharge outlets travels farther. Air is discharged across a wide area from the four sides of the unit.

Wide Flap

A wider main flap and sub flap reduce turbulence and increase airflow. Also, a wider angle jetting port allows airflow to reach as far as five meters.

* 4-Way Cassette : 3448PU type

Advantages for Outdoor Unit

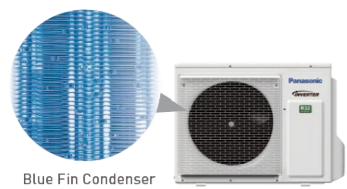

Blue Fin Condenser



High Durability Outdoor Unit

All Panasonic heat exchangers feature our Blue Fin technology, which offers enhanced corrosion resistance compared to non-Blue Fin models.

In-house manufactured compressor

Panasonic all in-house manufactured compressors are supplied to the world. The cumulative total of high-quality compressors in use has reached 580 million units*.

* As of September 2019. (In-house research)

Next Generation R32 Refrigerant

Compared to R22 and R410A, R32 has a very low potential impact on the depletion of the ozone layer and global warming.

Installation Instruction

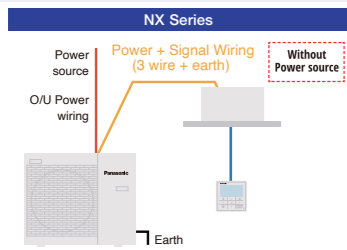

3 Wire Method

This NX series has been developed with 3 wire method and communication.

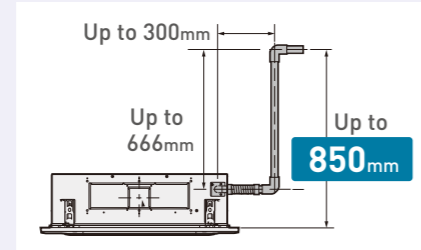

A strong and quiet drain pump

The drain pump can pump water up to a height of 850 mm, making drain pipe layout easy. Supports for 4-way Cassette



NEW!!! Operation Temperature

New NX series are capable of working even in the most difficult ambient conditions. Operating range expanded up to outdoor air temperature of 46°C.

4-WAY CASSETTE

- Industry-leading Powerful, 360° Wide & Comfortable Airflow.
- The drain pump can pump water up to a height of 850 mm, making drain pipe layout easy.

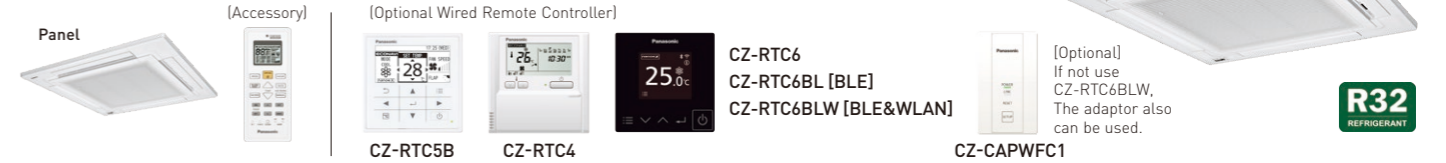

Capacity (Btu/h(Phase))	17,100	20,500	24,200	29,000	34,100	42,700	42,700 (3)	47,800	47,800(3)	
Power Source	V/Phase Hz		220-240V, 1Ø		Phase - 50Hz		380-415V, 3Ø Phase - 50Hz		220-240V, 1Ø Phase - 50Hz	
Indoor	S-1821PU3H	S-1821PU3H	S-2430PU3H	S-2430PU3H	S-3448PU3H	S-3448PU3H	S-3448PU3H	S-3448PU3H	S-3448PU3H	
Outdoor	U-18PR1H5	U-21PR1H5	U-24PR1H5	U-30PR1H5	U-34PR1H5	U-43PR1H5	U-43PR1H5	U-48PR1H5	U-48PR1H5	
Panel	CZ-KPU3H	CZ-KPU3H	CZ-KPU3H	CZ-KPU3H	CZ-KPU3H	CZ-KPU3H	CZ-KPU3H	CZ-KPU3H	CZ-KPU3H	
Cooling Capacity: Rated (Min-Max)	kW	5.00 [2.00-5.60]	6.00 [2.00-6.30]	7.10 [2.10-8.00]	8.50 [2.10-10.00]	10.00 [3.20-11.20]	12.50 [3.80-14.00]	12.50 [3.80-14.00]	14.00 [3.80-14.71]	14.00 [3.80-14.71]
	Btu/h	17,100 [6,820-19,100]	20,500 [6,820-21,500]	24,200 [7,170-27,300]	29,000 [7,170-34,100]	34,100 [10,900-38,200]	42,700 [13,000-47,800]	42,700 [13,000-47,800]	47,800 [13,000-50,200]	47,800 [13,000-50,200]
Current: Rated (Min-Max)	A	5.2-5.5	7.5-8.0	8.5-9.2	10.7-11.7	13.7-15.0	16.9-18.5	5.6-6.1	21.9-23.9	7.2-7.9
Power Input: Rated (Min-Max)	kW	1.14 [0.38-1.50]	1.71 [0.38-2.10]	1.99 [0.30-2.26]	2.52 [0.28-3.33]	3.23 [0.61-3.73]	3.74 [0.63-4.25]	3.74 [0.63-4.25]	4.83 [0.63-5.10]	4.83 [0.63-5.10]
CSPF		6.27	5.89	6.08	5.97	5.89	5.80	5.80	5.23	5.23
COP/EER	W/W	4.39	3.51	3.57	3.37	3.10	3.34	3.34	2.90	2.90
	Btu/hW	15.00	11.99	12.16	11.51	10.56	11.42	11.42	9.90	9.90
Indoor Unit										
Air Volume	m³/min	25.0	25.0	25.0	25.0	36.4	36.4	36.4	36.4	36.4
	cfm	882	882	882	882	1,285	1,285	1,285	1,285	1,285
Sound Pressure Level (Hi/L0)	dB (A)	42 / 35	42 / 35	42 / 35	42 / 35	47 / 41	47 / 41	47 / 41	47 / 41	47 / 41
Sound Power Level (Hi/L0)	dB	57 / 50	57 / 50	57 / 50	57 / 50	62 / 56	62 / 56	62 / 56	62 / 56	62 / 56
Dimension	Indoor (HxWxD)	mm	256 x 840 x 840	256 x 840 x 840	256 x 840 x 840	256 x 840 x 840	319 x 840 x 840	319 x 840 x 840	319 x 840 x 840	319 x 840 x 840
	Panel (HxWxD)	mm	44 x 950 x 950	44 x 950 x 950	44 x 950 x 950	44 x 950 x 950	44 x 950 x 950	44 x 950 x 950	44 x 950 x 950	44 x 950 x 950
	Panel	kg	21	21	21	21	24	24	24	24
Net Weight	Indoor	kg	5	5	5	5	5	5	5	5
	Panel	kg	5	5	5	5	5	5	5	5
Outdoor										
Sound Pressure Level	dB (A)	49	50	51	53	55	57	57	58	58
Sound Power Level	dB	68	69	70	72	74	76	76	77	77
Dimension	Outdoor (HxWxD)	mm	619 x 824 x 299	619 x 824 x 299	619 x 824 x 299	695 x 875 x 320	695 x 875 x 320	996 x 980 x 370	996 x 980 x 370	996 x 980 x 370
Net Weight	kg	29	29	33	39	48	68	67	68	67
Piping Connection	Gas Pipe	mm (inch)	12.70 (1/2)	12.70 (1/2)	15.88 (5/8)	15.88 (5/8)	15.88 (5/8)	15.88 (5/8)	15.88 (5/8)	15.88 (5/8)
	Liquid Pipe	mm (inch)	6.35 (1/4)	6.35 (1/4)	9.52 (3/8)	9.52 (3/8)	9.52 (3/8)	9.52 (3/8)	9.52 (3/8)	9.52 (3/8)
Pipe Length	Min-Max	m	5 - 30	5 - 30	5 - 30	5 - 50	5 - 50	5 - 50	5 - 50	5 - 50
Elevation Difference	m	20	20	20	20	30	30	30	30	30
Maximum Chargeless Length	Max	m	15	15	15	25	25	25	25	25
Additional Gas	g/m	10	10	10	30	30	30	30	30	30
Operation Range, Outdoor	Min-Max	°C	16-46	16-46	16-46	16-46	16-46	16-46	16-46	16-46

* Specifications are subject to change without notice. Please refer to technical documents for more details.
* The sound pressure level is measured in accordance with JIS C 9612 and JIS B 8616.

ADAPTIVE DUCTED

- Air intake from rear as standard. Industry-leading horizontal and vertical design.
- Powerful 150Pa ESP and space saving 250 mm height, filter included.
- Built-in Drain pump and selectable air inlet position (Bottom and Rear).

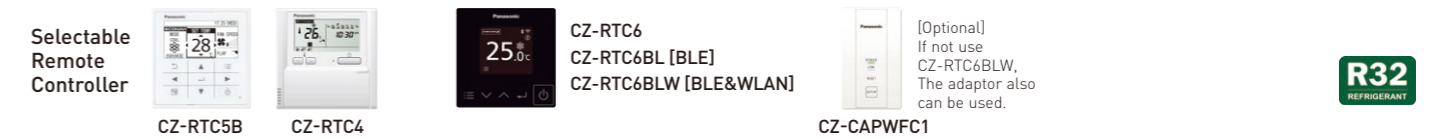

Capacity (Btu/h(Phase))	17,100	20,500	24,200	27,600	34,100	42,700	42,700 (3)	47,000	47,000(3)	
Power Source	V/Phase Hz		220-240V, 1Ø		Phase - 50Hz		380-415V, 3Ø Phase - 50Hz		220-240V, 1Ø Phase - 50Hz	
Indoor	S-1821PF3H	S-1821PF3H	S-2430PF3H	S-2430PF3H	S-3448PF3H	S-3448PF3H	S-3448PF3H	S-3448PF3H	S-3448PF3H	
Outdoor	U-18PR1H5	U-21PR1H5	U-24PR1H5	U-30PR1H5	U-34PR1H5	U-43PR1H5	U-43PR1H5	U-48PR1H5	U-48PR1H5	
Cooling Capacity: Rated (Min-Max)	kW	5.00 [2.00-5.60]	6.00 [2.00-6.30]	7.10 [2.00-7.60]	8.10 [2.00-8.90]	10.00 [3.20-11.20]	12.50 [3.80-13.50]	12.50 [3.80-13.50]	13.77 [3.80-14.20]	13.77 [3.80-14.20]
	Btu/h	17,100 [6,820-19,100]	20,500 [6,820-21,500]	24,200 [6,820-25,900]	27,600 [6,820-30,400]	34,100 [10,900-38,200]	42,700 [13,000-46,100]	42,700 [13,000-46,100]	47,000 [13,000-48,500]	47,000 [13,000-48,500]
Current: Rated (Min-Max)	A	6.8-7.2	8.6-9.1	9.7-10.5	11.1-12.1	13.3-14.5	17.9-19.6	5.9-6.5	21.6-23.6	7.1-7.8
Power Input: Rated (Min-Max)	kW	1.54 [0.41-1.75]	1.95 [0.41-2.30]	2.27 [0.34-2.48]	2.60 [0.33-2.90]	3.12 [0.59-3.65]	3.96 [0.65-4.35]	3.96 [0.65-4.35]	4.77 [0.65-4.95]	4.77 [0.65-4.95]
CSPF		5.02	4.65	5.21	5.21	4.74	5.02	5.02	4.74	4.74
COP/EER	W/W	3.25	3.08	3.13	3.12	3.21	3.16	3.16	2.89	2.89
	Btu/hW	11.10	10.51	10.66	10.62	10.93	10.78	10.78	9.85	9.85
Indoor Unit										
Air Volume	m³/min	16.0	16.0	21.0	21.0	36.0	36.0	36.0	36.0	36.0
	cfm	565	565	740	740	1,270	1,270	1,270	1,270	1,270
External static pressure	Pa	30 [10-150]	30 [10-150]	30 [10-150]	30 [10-150]	50 [10-150]	50 [10-150]	50 [10-150]	50 [10-150]	50 [10-150]
Sound Pressure Level (Hi/L0)	dB (A)	35 / 29	35 / 29	35 / 29	35 / 29	40 / 30	40 / 30	40 / 30	40 / 30	40 / 30
Sound Power Level (Hi/L0)	dB	58 / 52	58 / 52	58 / 52	58 / 52	63 / 53	63 / 53	63 / 53	63 / 53	63 / 53
Dimension	Indoor (HxWxD)	mm	250 x 800 x 730	250 x 800 x 730	250 x 1,000 x 730	250 x 1,000 x 730	250 x 1,400 x 730	250 x 1,400 x 730	250 x 1,400 x 730	250 x 1,400 x 730
Net Weight	Indoor	kg	25	25	30	30	39	39	39	39
Outdoor										
Sound Pressure Level	dB (A)	50	51	51	53	55	57	57	58	58
Sound Power Level	dB	69	70	70	72	74	76	76	77	77
Dimension	Outdoor (HxWxD)	mm	619 x 824 x 299	619 x 824 x 299	619 x 824 x 299	695 x 875 x 320	695 x 875 x 320	996 x 980 x 370	996 x 980 x 370	996 x 980 x 370
Net Weight	kg	29	29	33	39	48	68	67	68	67
Piping Connection	Gas Pipe	mm (inch)	12.70 (1/2)	12.70 (1/2)	15.88 (5/8)	15.88 (5/8)	15.88 (5/8)	15.88 (5/8)	15.88 (5/8)	15.88 (5/8)
	Liquid Pipe	mm (inch)	6.35 (1/4)	6.35 (1/4)	9.52 (3/8)	9.52 (3/8)	9.52 (3/8)	9.52 (3/8)	9.52 (3/8)	9.52 (3/8)
Pipe Length	Min-Max	m	5 - 30	5 - 30	5 - 30	5 - 50	5 - 50	5 - 50	5 - 50	5 - 50
Elevation Difference	m	20	20	20	20	30	30	30	30	30
Maximum Chargeless Length	Max	m	15	15	15	25	25	25	25	25
Additional Gas	g/m	10	10	10	30	30	30	30	30	30
Operation Range, Outdoor	Min-Max	°C	16-46	16-46	16-46	16-46	16-46	16-46	16-46	16-46

* Specifications are subject to change without notice. Please refer to technical documents for more details.
* The sound pressure level is measured in accordance with JIS C 9612 and JIS B 8616.

CEILING EXPOSED

- The slim design makes thickness only 235 mm.
- Compact Looking, Stylish, One-Motion Design.
- Comfortable, Long-Distance Airflow Distribution.

(Accessory) (Optional Wired Remote Controller)



[Optional] If not use CZ-RTC6BLW, The adaptor also can be used.



Capacity [Btu/h(Phase)]	17,100	20,500	24,200	29,000	34,100	42,700	42,700 (3)	45,500	45,500(3)	
Power Source	220-240V, 1Φ		220-240V, 1Φ		220-240V, 1Φ		220-240V, 1Φ		220-240V, 1Φ	
Indoor	S-1821PT3H	S-1821PT3H	S-2430PT3H	S-2430PT3H	S-3448PT3H	S-3448PT3H	S-3448PT3H	S-3448PT3H	S-3448PT3H	
Outdoor	U-18PR1H5	U-21PR1H5	U-24PR1H5	U-30PR1H5	U-34PR1H5	U-43PR1H5	U-43PR1H8	U-48PR1H5	U-48PR1H8	
Cooling Capacity: Rated (Min-Max)	kW		kW		kW		kW		kW	
Current: Rated (Min-Max)	A		A		A		A		A	
Power Input: Rated (Min-Max)	kW		kW		kW		kW		kW	
CSPF	A		A		A		A		A	
COP/EER	W/W		W/W		W/W		W/W		W/W	
Indoor Unit	m ³ /min		m ³ /min		m ³ /min		m ³ /min		m ³ /min	
Air Volume	cfm		cfm		cfm		cfm		cfm	
Sound Pressure Level (Hi/Lo)	dB (A)		dB (A)		dB (A)		dB (A)		dB (A)	
Sound Power Level (Hi/Lo)	dB		dB		dB		dB		dB	
Dimension	Indoor (HxWxD) mm		Indoor (HxWxD) mm		Indoor (HxWxD) mm		Indoor (HxWxD) mm		Indoor (HxWxD) mm	
Net Weight	Indoor kg		Indoor kg		Indoor kg		Indoor kg		Indoor kg	
Outdoor	Sound Pressure Level dB (A)		Sound Pressure Level dB (A)		Sound Pressure Level dB (A)		Sound Pressure Level dB (A)		Sound Pressure Level dB (A)	
Sound Power Level	dB		dB		dB		dB		dB	
Dimension	Outdoor (HxWxD) mm		Outdoor (HxWxD) mm		Outdoor (HxWxD) mm		Outdoor (HxWxD) mm		Outdoor (HxWxD) mm	
Net Weight	kg		kg		kg		kg		kg	
Piping Connection	Gas Pipe mm (inch)		Gas Pipe mm (inch)		Gas Pipe mm (inch)		Gas Pipe mm (inch)		Gas Pipe mm (inch)	
Pipe Length	Liquid Pipe mm (inch)		Liquid Pipe mm (inch)		Liquid Pipe mm (inch)		Liquid Pipe mm (inch)		Liquid Pipe mm (inch)	
Elevation Difference	m		m		m		m		m	
Maximum Chargeless Length	Max m		Max m		Max m		Max m		Max m	
Additional Gas	g/m		g/m		g/m		g/m		g/m	
Operation Range, Outdoor	Min-Max °C		Min-Max °C		Min-Max °C		Min-Max °C		Min-Max °C	

* Specifications are subject to change without notice. Please refer to technical documents for more details.
 * The sound pressure level is measured in accordance with JIS C 9612 and JIS B 8616.

Remote controller information

		Compatibility Table		
		CZ-RTC6BLW Built-in BLE & WLAN	CZ-RTC6BL Built-in BLE	CZ-RTC6
CONEX Type				—
App				—

• Power supply is available only when using NX IDU
 * Available as a spare part

Wireless Remote Controller



Wired Remote Controller

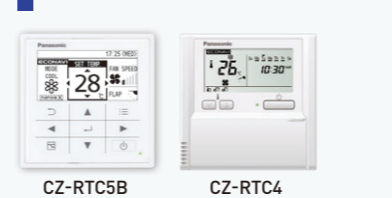

4-WAY CASSETTE **NEW** Dimensions

- A S-1821PU3H/S-2430PU3H
- B S-3448PU3H

- Air intake
- Discharge outlet
- Refrigerant tubing (liquid tube)
- Refrigerant tubing (gas tube)
- Drain tube connection port VP25 (outer dia. ø32)
- Power supply port
- Suspension bolt hole (4-12x30 elongated hole)

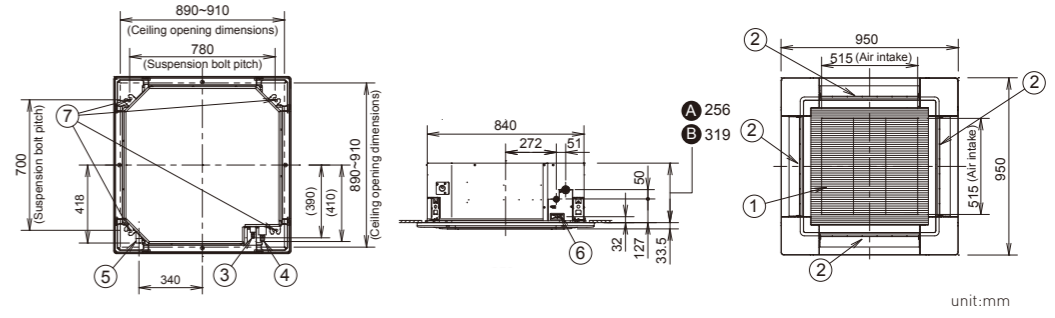

<Filter dimension> 520 x 520 x 15

ADAPTIVE DUCTED **NEW** Dimensions

S-1821PF3H/S-2430PF3H/S-3448PF3H

Detailed dimensions of indoor unit

Type	A mm	B mm	C mm	D mm	E mm	F Qty
1821	867	800	450 (Pitch 150 x 3)	71	592	12
2430	1,067	1,000	750 (Pitch 150 x 5)	21	792	16
3448	1,467	1,400	1,050 (Pitch 150 x 7)	71	1,192	20

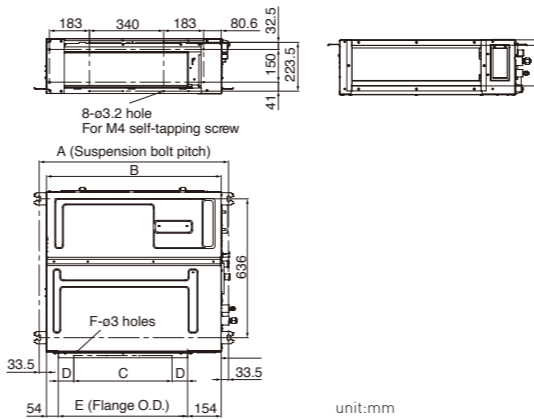

CEILING EXPOSED **NEW** Dimensions

S-1821PT3H

S-2430PT3H

S-3448PT3H

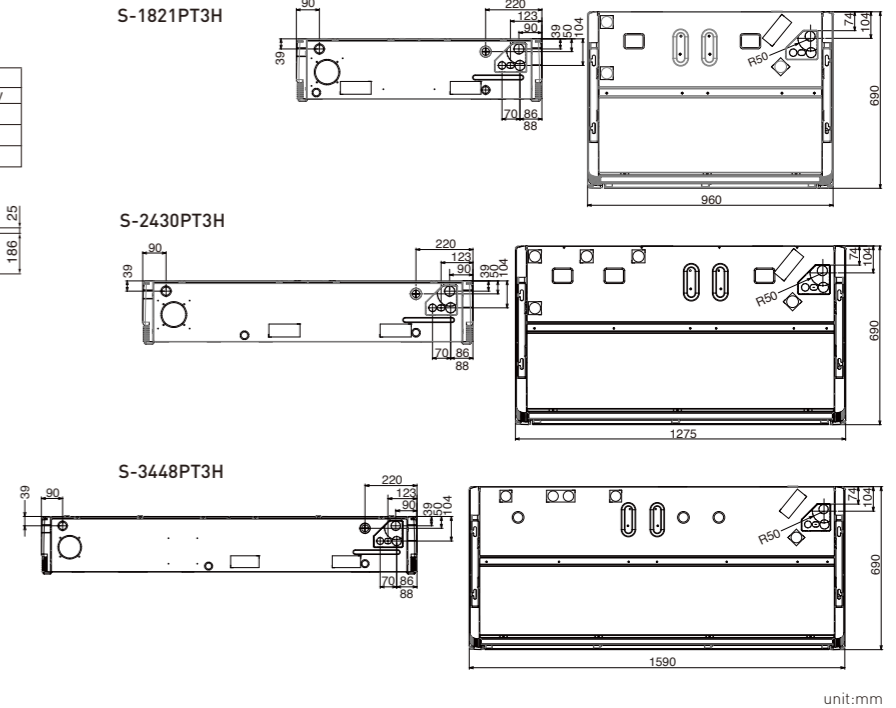

OUTDOOR UNITS **NEW** Dimensions

U-18PR1H5/U-21PR1H5/U-24PR1H5

U-43PR1H5/U-43PR1H8/U-48PR1H5/U-48PR1H8

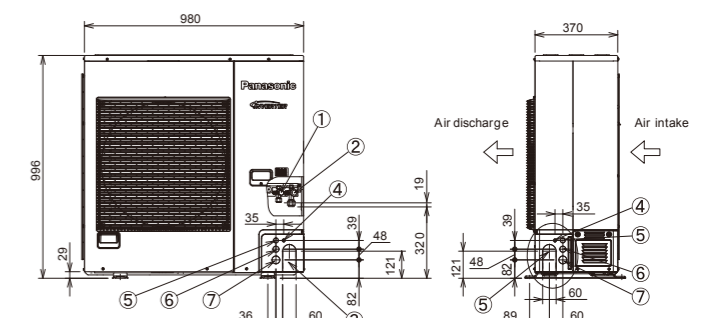
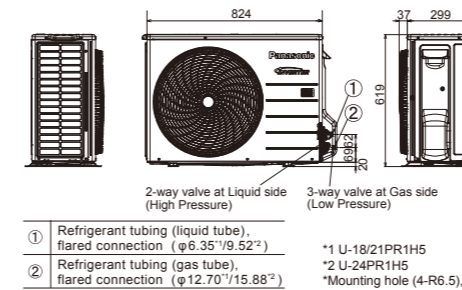

U-30PR1H5/U-34PR1H5

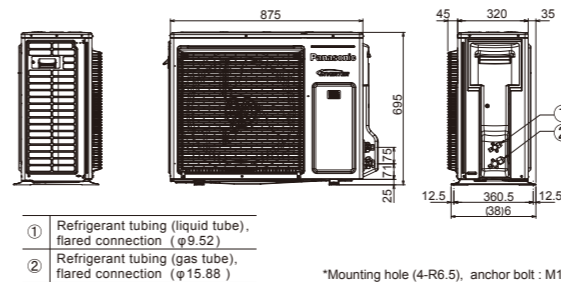

- Refrigerant tubing (liquid tube), flared connection (ø9.52)
- Refrigerant tubing (gas tube), flared connection (ø15.88)
- Refrigerant tubing port
- Electrical wiring port (ø13)
- Electrical wiring port (ø22)
- Electrical wiring port (ø27)
- Electrical wiring port (ø35)

*Mounting hole (4-R6.5), anchor bolt : M10

*Mounting hole (4-R6.5), anchor bolt : M10

unit:mm